

DESIGN AND IMPLEMENTATION OF A MICROPROCESSOR BASED ROOM ILLUMINATION CONTROL SYSTEM

E. O. Owiti¹, J. N. Mutuku¹ and R. M. Onger¹

¹Jomo Kenyatta University of Agriculture and Technology, Nairobi, Kenya

E-mail: edwiti16@gmail.com

Abstract

This paper describes the development of a microprocessor based room illumination control system that offers advantage of improved efficiency in the use of electrical energy and reduced cost of electricity over manually controlled lighting systems. This system is developed to regulate the intensity of light from direct current (DC) bulbs when the presence of a person(s) is detected in the room so that ambient light is always maintained between 135 lux and 300 lux. Lights are however completely turned OFF if the ambient light level is beyond this range. At the heart of this system is an Intel 8085 microprocessor which controls all operations of the system. The infrared and the passive infrared (PIR) sensors are used to detect the occupancy status of the room while the visible light sensor is used to detect the ambient light level in the room. The PIR sensor is mounted at a height of about 2 m which prevents the system from detecting the presence of animals like cats and dogs in the room and therefore avoids turning the lights ON falsely. Analog signals are produced as outputs from the three sensors and are fed to the microprocessor unit (MPU) for processing through the analog-to-digital converter (ADC). The MPU is then capable of controlling all operations and automating the system. The entire hardware functioning is coordinated by a software program written in low level 8085 assembly language and stored in the erasable programmable read only memory (EPROM). Implementing this system improves efficiency in the use of electrical energy and reduces the cost of electricity.

Key words: Microprocessor based system, occupancy dependent, illumination control, PIR Sensor, visible light sensor

1.0 Introduction

Electrical and light energy management is becoming increasingly popular as means of saving and reducing the cost of energy and electricity. Proper habits like turning lights OFF when there are no person(s) in the room is one of the ways of conserving the electrical energy to avoid energy waste (Athanasios, 2002; Galasiu *et al.*, 2007). In many multifunctional rooms however, poor habits of using the light energy still contribute to an extra cost of electricity, that is, lights are switched ON at full intensity when there is too much natural light and sometimes when there are no person(s) in the room.

Microcontrollers and Microprocessor based systems are increasingly being used to provide solutions where manual systems have failed to provide efficient solutions (Teerasilapa *et al.*, 2002; Shoewu, 2006; Mohamed, 2008; Inderpreet, 2010). Consumption of light energy in appropriate amounts and in the most needed time is desirable to increase the energy efficiency and cost effectiveness. It is desirable that the lights in a room are only turned ON if there is a person(s) in the room, and the intensity of this light be adjusted to a desired level depending on the intensity of the light coming in through the windows and doors. Thus, in this project, a system is designed with transducers for detecting the presence of a person(s) in the room using a PIR sensor (also senses motion) and an infrared sensor and measuring the ambient light level in the room, using a photoconductive detector in form of a light dependent resistor (LDR), before adjusting the bulb intensity to a desired level. An energy saving DC bulb is used to provide the desired level of light in order to supplement the natural light in the room.

The central processing unit (CPU) of the system can only be able to read digital signals. However, the outputs of the three sensors provide analog signals and must first be converted to digital forms by an analog-to-digital converter (ADC) for proper interfacing. The digital data obtained from the infrared sensor and PIR sensor are first added to give a value which is compared to a reference digital value so that if the sum is greater than this reference value, the information is translated to mean that there is a person(s) in the room and lights can be turned ON. In this design, it is desired that the ambient light in the room be maintained between illuminance values of 135 lux and 300 lux which is in the range sufficient for normal reading (Sinclair, 2001). The converted digital data obtained from the light sensor is then compared, continuously, with the digital equivalent of the illuminance range in form of a look-up table to maintain the ambient light as desired.

For the proper working of the microprocessor and other modules and also to ensure adequate and efficient illumination control, a robust software core is essential. The design works with software written in low level-8085 assembly language program which is stored in the EPROM.

2.0 Materials and methods

The overall system hardware components are assembled and interfaced as shown in Figure 1.

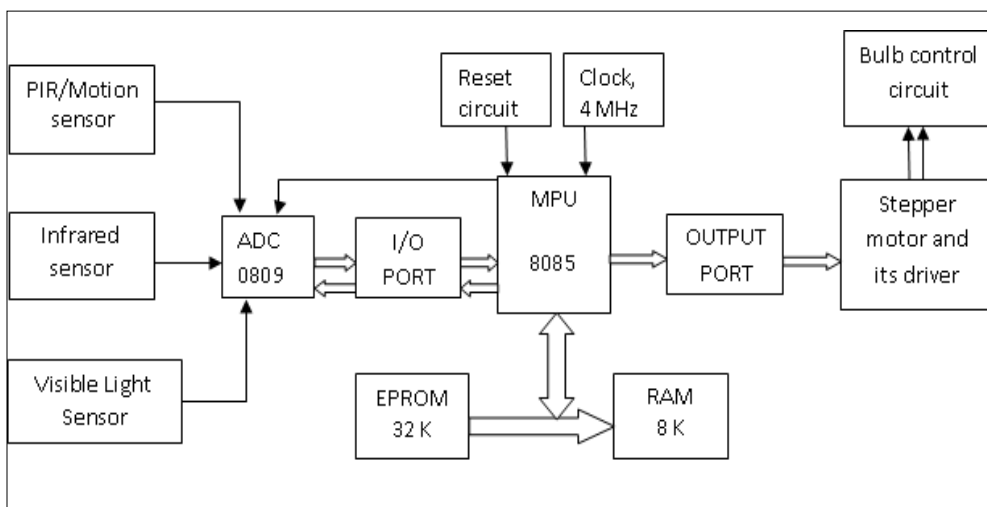

Figure 1: Block diagram showing interface of main components in the design

2.1 The Microprocessor Unit (MPU)

The Intel 8085 microprocessor implements the control algorithm by regulating the light intensity from the bulbs according to the amount of natural light coming in through windows and doors. It also determines when information is to be read from the three sensors; infrared sensor, PIR sensor and the visible light sensor. It controls the ADC operation by sending signals to it for start of conversion (SOC), address latch enable (ALE) and receives the end of conversion (EOC) signals. After the MPU processes data in it, it determines the form of operation on the stepper motor through the output port B. The ADC needs to operate at a much slower frequency (500 kHz) compared to the MPU which takes in clock frequency of 4 MHz and gives out a frequency of 2 MHz through its pin 37. It is from this 2 MHz frequency that 500 kHz is obtained through frequency divider circuit designed using D-Flip flops.

2.2 The ADC0809 Interface

The ADC needs interfacing through a microprocessor to convert analog data into digital format. The ADC0809 is an 8-bit analog to digital converter having data lines D0-D7 and works on the principle of successive approximation. It has a total of eight analog input channels out of which only one can be selected using address lines A, B and C. Here, in this case, input channels IN4, IN5 and IN6 were set for the visible light sensor, PIR Sensor and infrared sensor and were selected using codes 00H, 04H and 08H respectively. The visible light sensor provides an analog output voltage that is proportional to the ambient light level falling on it. It is this analog

voltage that is fed into the ADC via pin 2 for conversion before the data is taken for processing by the microprocessor. Similarly, the infrared sensor provides an analog output voltage that is proportional to the infrared radiation falling on its surface from human body and is fed into the ADC via its pin 4. The PIR sensor opens its dry contact switch upon detection of any motion and infrared in its field of view. This opened switch is connected to the transistor-relay network to provide a 2.0 V analog voltage for conversion. This value, together with the data from the infrared sensor, is used to determine whether or not the room is occupied.

2.3 Memory modules

The two chips used as memory modules are the EPROM and the random access memory (RAM). The EPROM is used to store the program used to run the entire system and must store program codes that are compatible with the Intel 8085 microprocessor. In this project, 27C256B was used as the EPROM to provide a memory space of 32 k. The RAM was used to provide the working space. This includes space for locating the STACK and location for temporary storage of data. This was a 6264 RAM chip which provided 8 k of memory space. Based on this memory space allocation a memory map is as follows,

EPROM: 0000H to 7FFFH

RAM: 8000H to 9FFFH

Unavailable: A000H to FFFFH

2.4 The 8255 Parallel Input Output (PIO) Interface

The main interface chips to this device are the ADC0809, the motor control lines and the ON /OFF relay switch. Two 8255 parallel input output (PIO) ports have been used in this design, one for interfacing the ADC0809 and the stepper motor and the other for interfacing with the relay for turning ON or OFF of the lights as shown in Figure 2. The first PIO is the main link chip and has its port A and port C – upper configured as inputs and ports B and C – lower configured as inputs. The code used to initialize this port is therefore 98H which must be loaded into its control register at the beginning of system program. The second PIO is used with all its ports configured as outputs and therefore code 80H is first loaded to its control register at the beginning of system program.

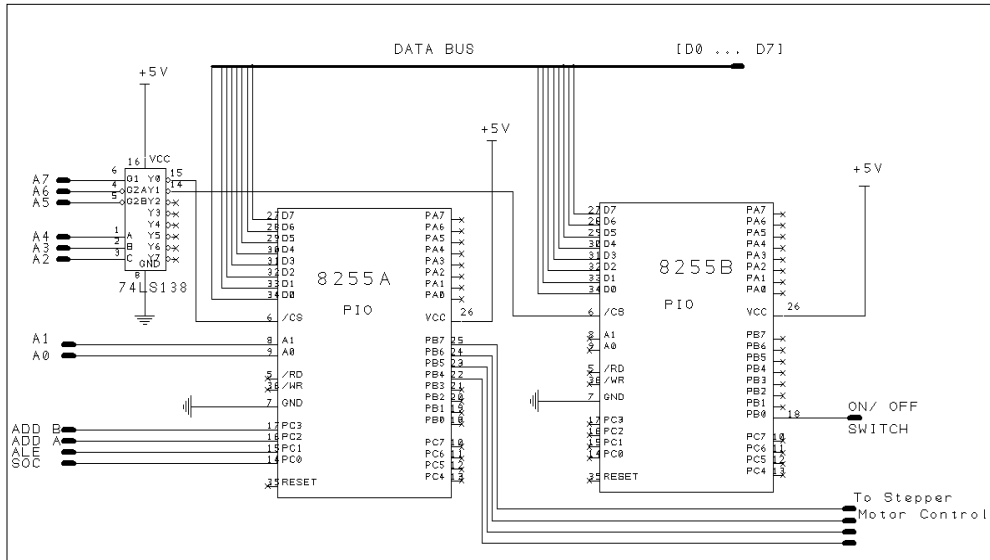

Figure 2: The 8255 PIO interfacing schematic circuit

2.5 Bulb Control Unit

The brightness control unit is responsible for the ultimate control of the ambient light in the room. The stepper motor, interfaced with its driver, is the actuator that links the microcomputer system to the bulb control unit. The unit uses a 555 timer integrated circuit (IC) to generate high frequency (150 Hz) pulse width modulated (PWM) signals with varying duty cycles which determine the brightness levels of the bulbs. Duty cycle of 50% and above makes the intensity of the bulbs to be increased whereas a smaller duty cycle makes the DC bulbs dimmer. In Figure 3, the direction of rotation of the stepper motor controls the resistance into the unit through a potentiometer which determines the value of the duty cycle.

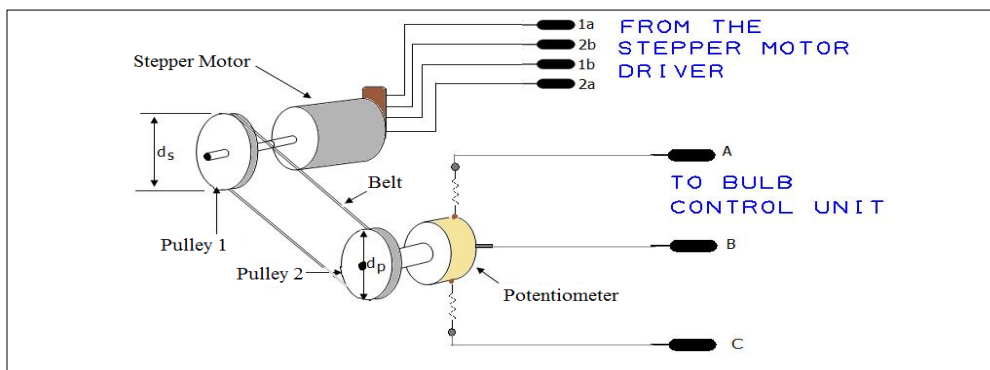

Figure 3: The Stepper motor control of the potentiometer

2.6 Software development

One of the most important aspects in this software development is the location of beginning point of different sections of the program and how to synthesize all functions in one program. Basically, the three fundamental procedures in software development were followed. This includes; algorithm design, flowchart design and assembly mnemonics design.

The program is divided into five main parts: PIO port initialization, stack definition and preparation of flag and storage registers; PIR/motion sensing through the ADC and data storage; infrared sensing through the ADC, data retrieval and arithmetic operation; visible light sensing through the ADC; data comparison and action on stepper motor. Figures 4 and 5 show the first two sections.

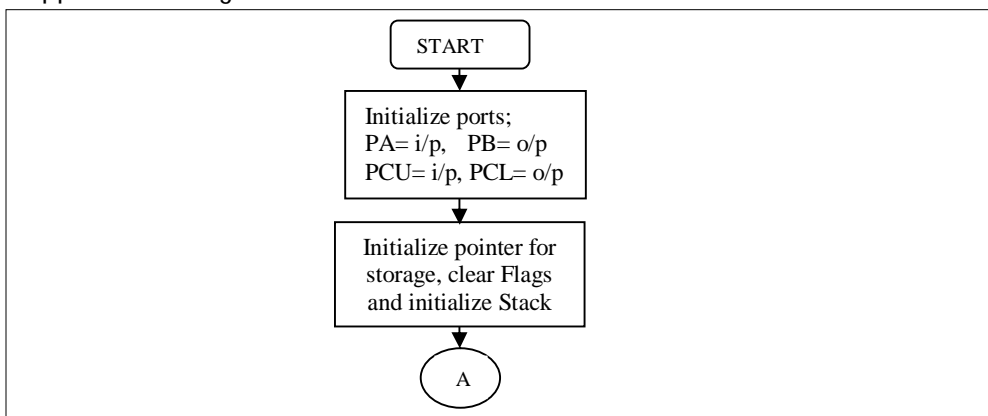

Figure 4: Flowchart showing initialization of ports, flags and stack

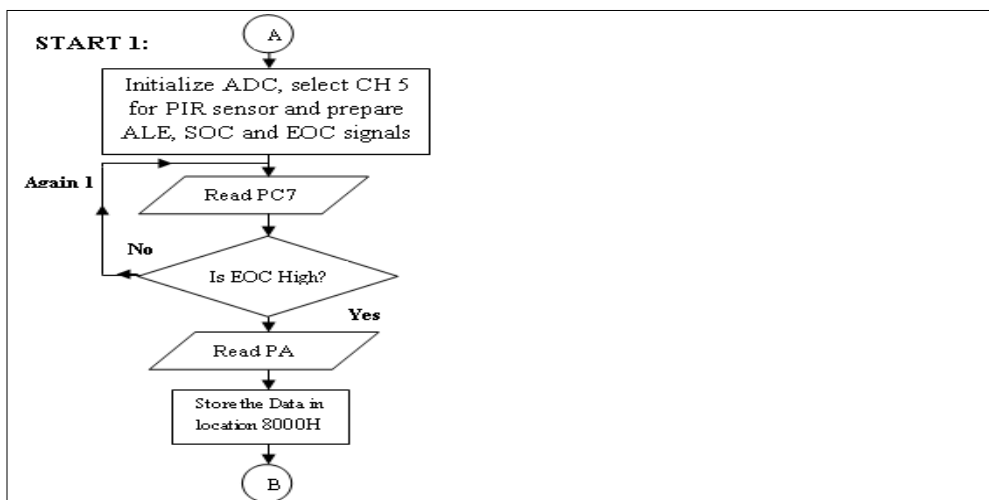

Figure 5: Flowchart showing data flow from PIR Motion sensor through the ADC

Figure 6 shows the third part of the software design which involves reading data from the IR sensor and retrieving the first data from the PIR sensor for addition

before the sum is compared with a minimum threshold of 68H which is an equivalent of 2 V switched ON by the relay

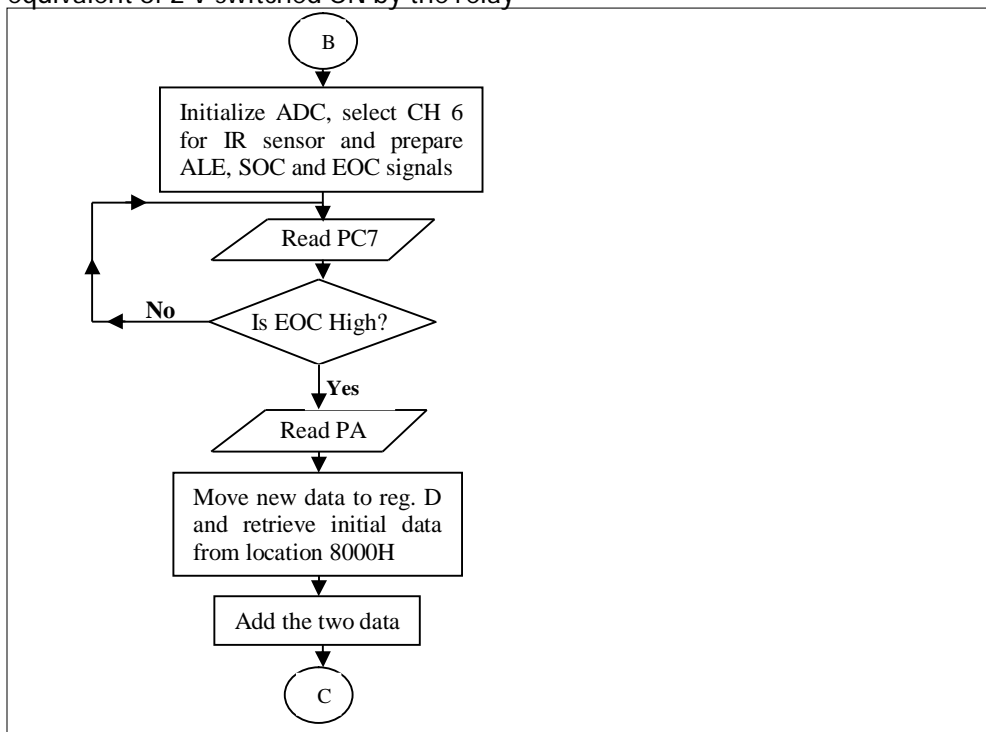

Figure 6: Flowchart showing data acquisition from the IR sensor through the ADC

Figure 6 shows the third part of the software design which involves reading data from the IR sensor and retrieving the first data from the PIR sensor for addition before the sum is compared with a minimum threshold of 68H which is an equivalent of 2 V switched ON by the relay.

The fourth and fifth portions are where the data is read from the visible light sensor and the data is used to determine the amount of light needed from the bulbs. The data that is read is compared with some three threshold values; 1AH, 20H and 30H corresponding to 400 lux, 300 lux and 135 lux respectively as shown in Figures 7 and 8. When data, from the visible light sensor, is less than 20H, the microprocessor unit drives the stepper motor in forward direction to reduce the amount of light. When the data is more than 30H, the microprocessor unit drives the stepper motor in reverse direction to increase the amount light. Data less than 1AH, initiates the relay, ON/OFF switch, to turn OFF the lights. The entire process is repeated continuously until the system is switched OFF.

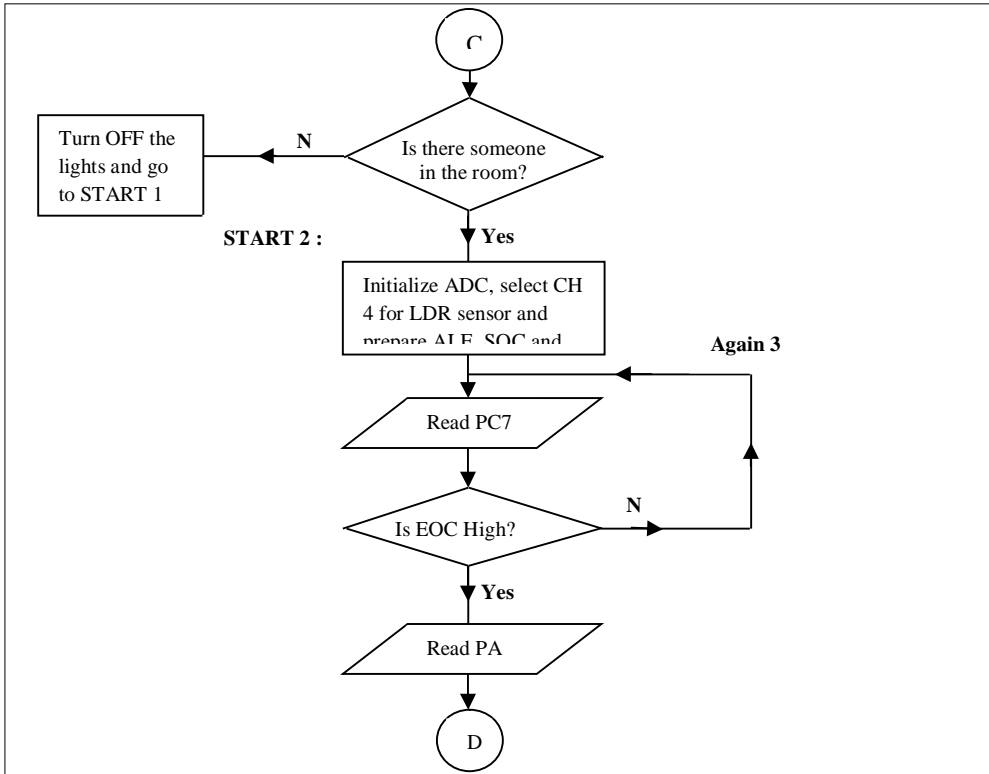

Figure 7: Flowchart showing occupancy determination and LDR data acquisition

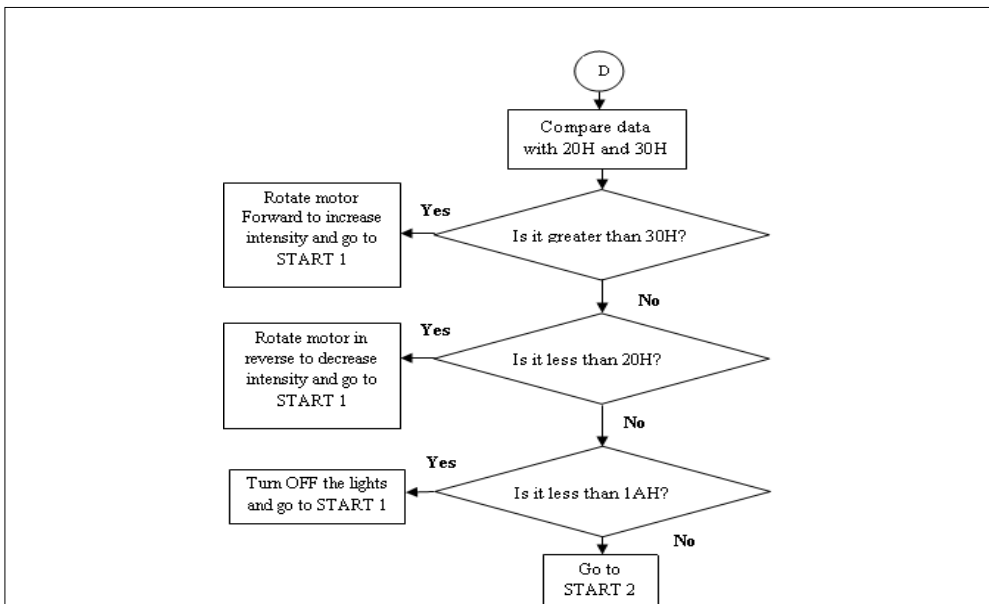

Figure 8: Flowchart showing the outcome of the illumination data obtained

The assembly code representing the individual blocks of the flowcharts was then written using 8085 assembly language.

3.0 Results and Discussion

3.1 Illuminance as a function of resistance

The values of LDR resistance were measured with an ohmmeter and the corresponding illuminance values were measured using a luxmeter, under different light levels and presented in a graph. This transducer was positioned at a height of about 1.5 m from the DC bulb and within base area of about 6.25 m² (2.5 m² X 2.5 m²). Only low light levels, from 100 lux to 10 klux, were calibrated using Solar Tex 11W energy saving DC bulb. This bulb has a 6500 K color temperature and resembles the black body radiation. The mathematical relation between the resistance of the sensor and the illuminance was then obtained by drawing the line of best fit as shown in Figure 9.

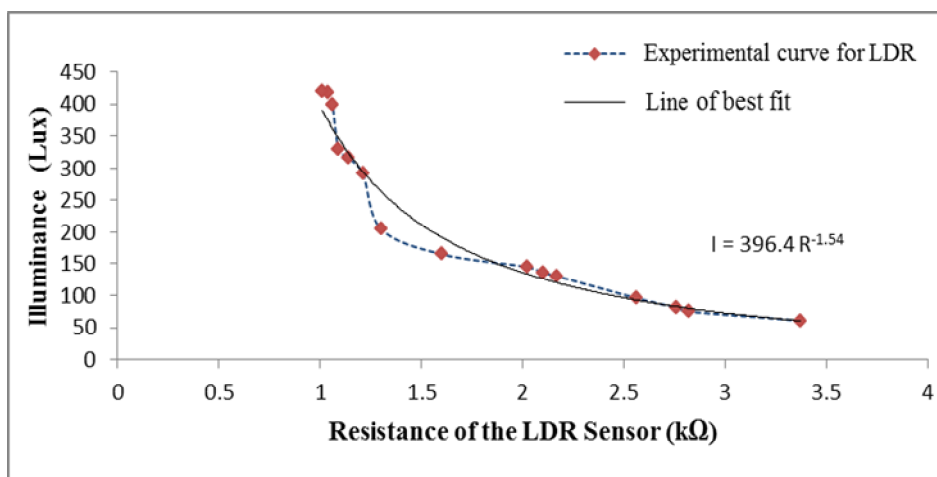

Figure 9: Graph of illuminance against the light sensor resistance

It was observed that the graph of illuminance against the resistance of the LDR followed an exponential decay pattern with minimum illuminance producing maximum resistance across the LDR. Equation 1 below was obtained as the result of the resistance-illuminance relationship of the sensor derived from Figure 9.

$$I = 396.4 R^{-1.54} \dots\dots\dots (1)$$

This equation defines the spectral responsivity of the visible light sensor (LDR) which determines how much of the detector input range is allowed with the corresponding output range (Ciampini *et al.*, 2005).

2.7 Calibration of the bulb unit

The potential difference across the bulb was monitored and result recorded using the digital multimeter device. This variation in the potential difference was being effected as a result of varying illumination in the room. The data obtained was recorded and a graph of the potential difference across the load against the illuminance was then drawn as shown in Figure 10. This graph exhibits four regions: In the first region (Region 1) the potential difference decreases from a maximum value of 11.8 V to about 11.2 V with a near zero gradient. In this region the bulbs are turned ON to full intensity; the second region (Region 2) defines the optimum ambient light in the room from 135 lux to 298 lux and the potential difference decreases with increase in illuminance; in the third region (Region 3) the gradient is more steeper compared to regions 1 and 2 up to 400 lux where there is a 'kink'; Region 4 defines the region where the bulb is completely turned OFF when the illuminance is above 400 lux.

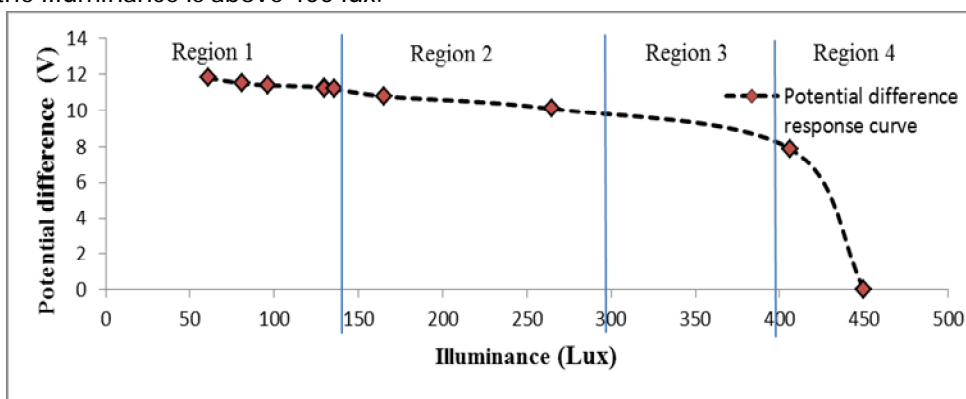

Figure 10: Graph of the potential difference against illuminance of the room

2.8 Sample consumption data

After successful calibration of the bulb unit, the system was then subjected to a real test. In this test, the system was set and left to regulate the illumination in a room. The potential differences across the load (bulb) and across the light sensor were recorded using a data logger for about six hours. During the test, the bulb was turned ON after the first 60 minutes. This was done to make it easy to verify whether the data logger was recording the intended data or not. Light falling on the sensor reduced the resistance across it and this produced a regulated potential difference across the bulb as shown in the graph of Figure 11.

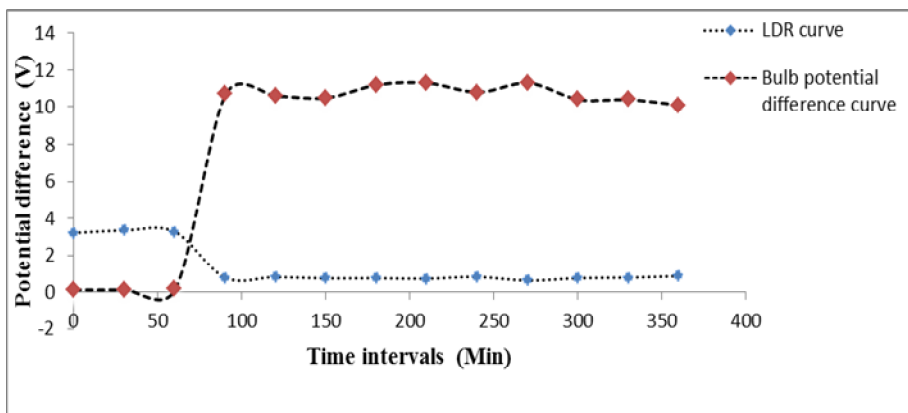

Figure 11: Regulated potential difference across the Bulb

2.9 Power consumption analysis

In analysis of the amount of power consumed in a regulated lighting system and unregulated lighting system, the potential difference across the bulb in the two systems is used as the main quantity for comparison i.e. 12.0 V for an unregulated system and 11.2 V average voltage obtained from Figure 11 for a similar and regulated system. Using Equation 2 and a measured resistance of 1860 Ω of the energy saving bulb, the power consumed in the two systems was calculated and recorded as shown in Table 1.

$$P = \frac{V^2}{R} \dots\dots\dots (2)$$

Table 1 Power consumption analysis

| | Regulated lighting system (Automated) | Unregulated lighting system (Manual) |
|--------------------------|---------------------------------------|--------------------------------------|
| Potential difference (V) | 11.2 | 12.0 |
| Bulb resistance (Ω) | 1860 | 1860 |
| Power consumed (W) | 0.067 | 0.077 |

From Table 1, it is evident that an unregulated lighting control system consumes more electric power than the regulated and automated lighting system. Indeed, this difference is presented as a percentage as follows.

$$\text{percentage difference} = \frac{(0.077 - 0.067)}{0.077} \times 100 = 12.99\%$$

This value means that an automated light control system or the microprocessor based light control system is much more efficient for use as an energy saving strategy by saving about 13% of the energy that would have rather gone to waste.

3.0 Conclusion

The design and implementation of a microprocessor based room illumination control system has been achieved. The design has been tested successfully on a real environment (Physics research laboratory) and produced the expected outcome. In this design, changes in the illumination level outside the room are synchronized with the artificial light from the bulbs. The ambient light detected by the LDR and measured by the luxmeter is a sum total of both the natural light and the artificial light. The relationship between the resistance and illuminance of the LDR sensor was obtained and observed to follow an exponential curve with 396.4 obtained as the proportionality constant and -1.54 as the exponential constant.

The hardware design was developed in modules using six breadboards and fourteen ICs. The software was designed based on the Intel 8085 microprocessor assembly language. Testing of the developed hardware was done by coding and storing a four byte program in the EPROM. A light emitting diode (LED) was then connected on the serial output data (SOD) terminal of the microprocessor, in common cathode mode, to enable the program produce a visible output when it is executed. The LED was turned ON immediately as expected to show that the hardware was properly designed on the breadboards.

In summary, a new automated light control system has been developed based on the 8-bit, Intel 8085, microprocessor with supporting software. This system addresses two main shortcomings in a manually controlled lighting system; lack of light dimming mechanism that controls light intensity from the bulbs depending on the level of natural light in the room and lack of an automated occupancy-dependent light control unit. These challenges introduce a 13% increase in the light energy consumption and to the cost of electricity. A 16-bit or a 32-bit microprocessor based system would function in a similar way and yield same result but would be more preferred when more functions are required in the system. This would also improve the system's operating frequency and computing capability.

Acknowledgements

The authors are grateful to the Physics Department and the Electronics Department of the Jomo Kenyatta University of Agriculture and Technology and the Microelectronics Department of the Kenya Polytechnic University College for their invaluable time and equipment support of this project.

References

Athanassios T. (2002). *A methodology for calculating room illuminance distribution and light dimming for a room with a controlled shading device*. MSc Thesis. Concordia University, Quebec, Canada.

Ciampini F., Scarazzato P. S. and Neves A. A. R., (2005). *Low cost data acquisition module for evaluating the quantitative performance of daylight systems*. In: *Passive and Low Energy Architecture*. Proceedings of the 22nd conference, November 13-16, Beirut, Lebanon. pp. 1-6.

Galasiu A. D., Guy R. N., Cristian S. and Daniel M. S. (2007). *Energy Saving Lighting Control System for Open-Plan Offices, a field study*, *Journal of Illuminating Engineering Society of North America-Leukos*, **4**, pp.7-29.

Gana J. K, (2007). *Development of a Light Dependent Automatic-Off Timer for House Holds Electronics*, *Leonardo Electronic Journal of Practices and Technologies*, **7**, pp.129 - 138.

Mohamed F., Mounir B. S. and Mouldi B., (2008). *Microcontroller Based Heart Rate Monitor*. *The International Arab Journal of Information Technology*, **5**, pp. 153-157.

Shoewu O. and Baruwa O. T., (2006). *Design of a Microprocessor Based Automatic Gate*, *The Pacific Journal of Science and Technology*, **7**, pp.31-44.

Sinclair I. (2001). *Sensors and Transducers*, Butterworth-Heinemann, London, pp. 58-59.

Teerasilapa D., Sumalee U. and Worapong T., (2002), *Microcontroller based liquid level control Modeling*, *Journal of King Mongkut's Institute of Technology North Bangkok (KMUTNB)*, **12**, pp. 1-4.